

COMBO

MODULAR SHOWCASE



Flexible Modular Showcase System



COMBO is our new modular museum showcase system, designed for elegant single or multi-module display arrangements. Its clean aesthetic is paired with high conservation performance, including passive climate control and a very low air exchange rate. Each module can be fitted with optional lighting and shelving to suit the object and curatorial concept perfectly. Flexible, robust and easy to handle, COMBO offers museums and heritage a sophisticated and scalable display solution.



Description of COMBO Modular Case

Module dimension: **90 x 90 x 210 cm**

Glass parameters:

Glass 55.4 (11,5mm) thickness, 4 x PVB films: 5 mm glass / 1,52 mm PVB / 5 mm glass

As an option 66.4 (13,5) thickness, 4 x PVB films: 6 mm glass / 1,52 mm PVB / 6 mm glass

Standard:

- Hinged door
- 0,1 AER
- Passive climate control
- movable with pallet jack

Options:

- Lighting (top and/or bottom or on sides)
- Shelves
- Glass P6B

Examples of Module Configuration

Single module



Double module

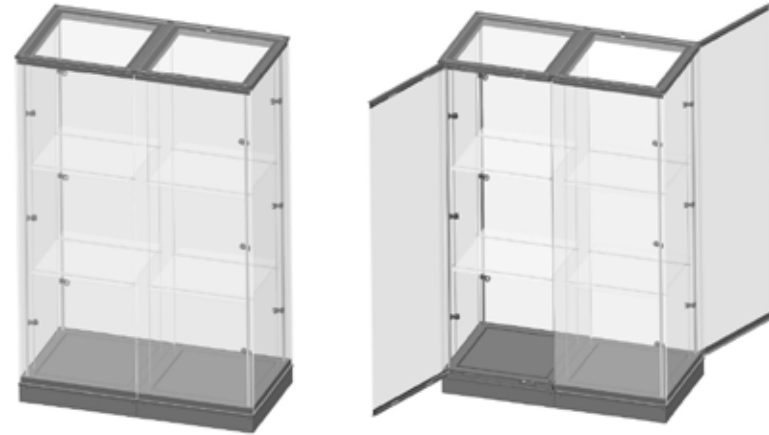

Triple module

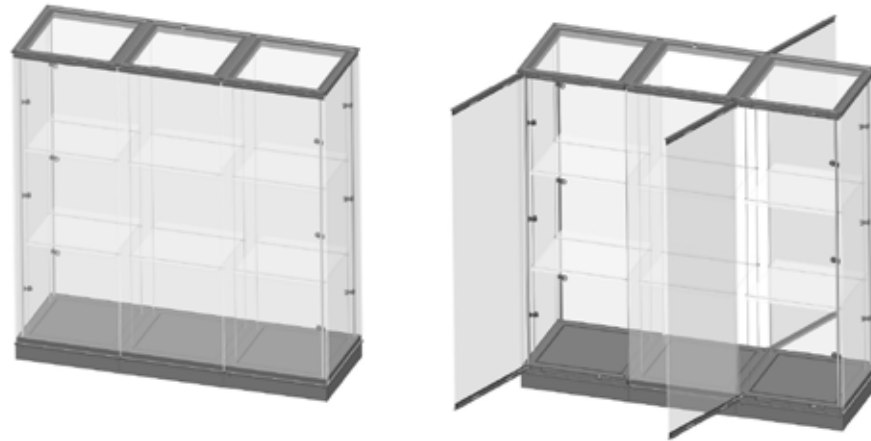

The modular showcase allows for construction of complex showcases in various shapes, composed of multiple modules. Each module can be independently equipped with internal lighting and shelving.



Quadruple module

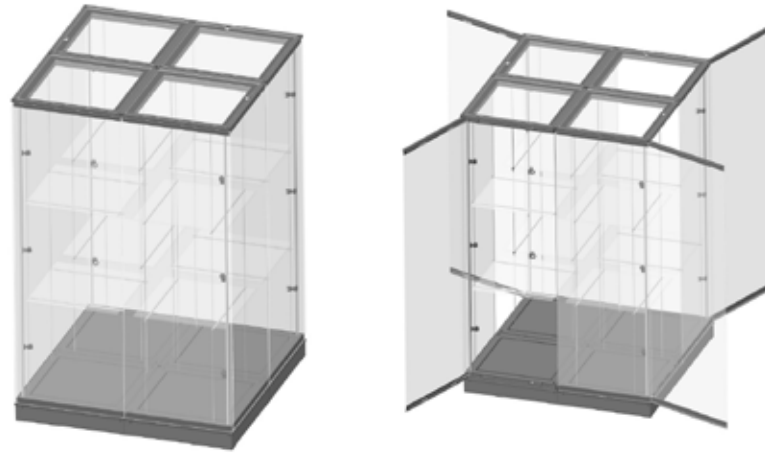

Much more
module
configurations
possible...

Six modules in a row

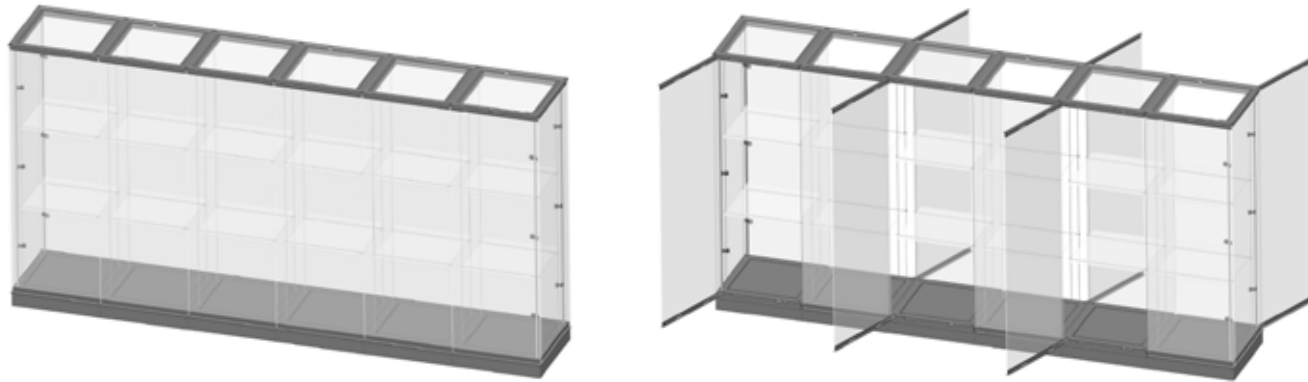

DISPLAY CASE - COMBO

Exploded view

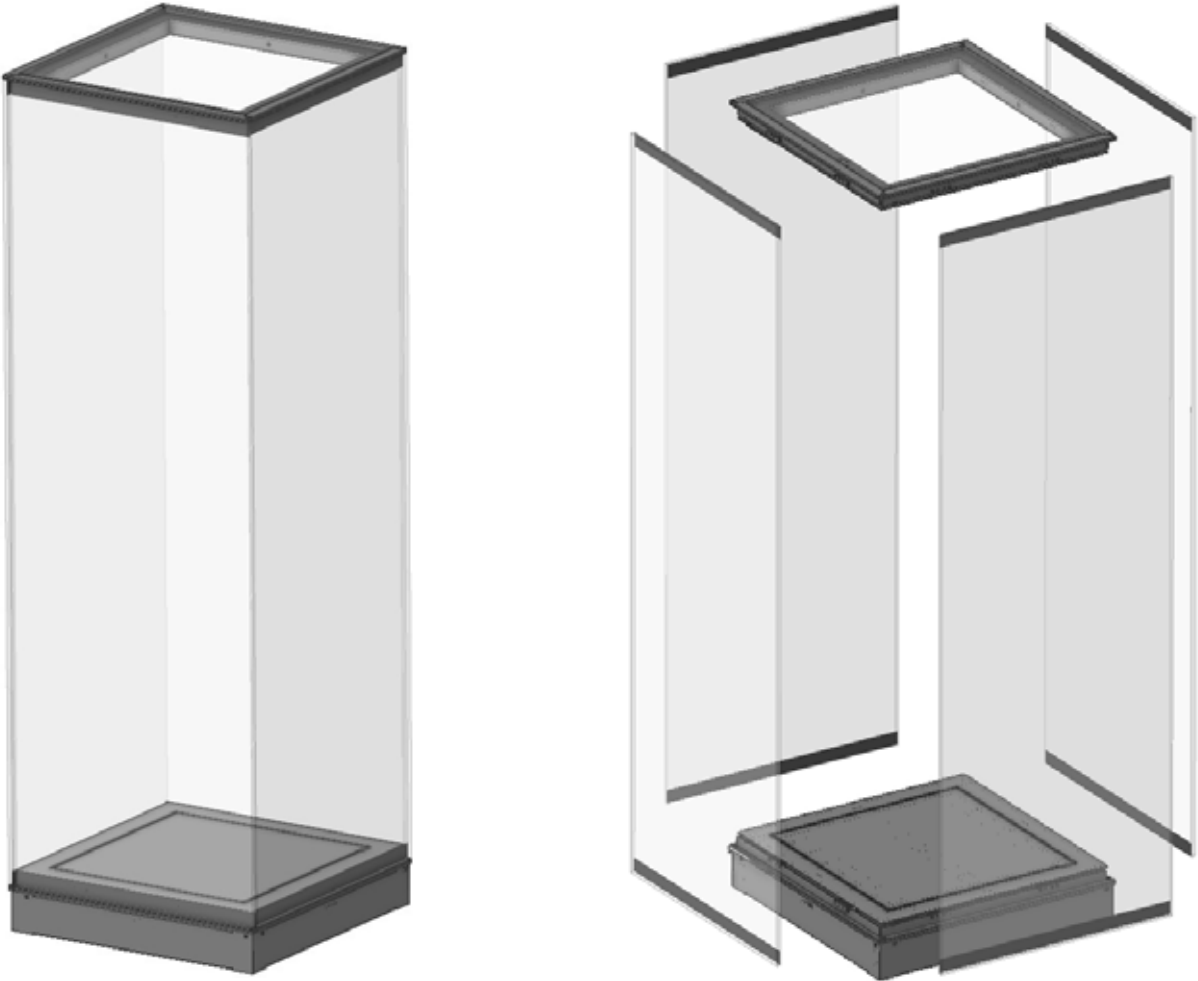

Specification of the frame (metal, dimensions, coatings):

Aluminum and steel custom-made profiles, cut using a CNC laser machine, are assembled into one piece mainly by gluing and bolting. All metal elements are powder-coated in the requested RAL colour.



Top frame

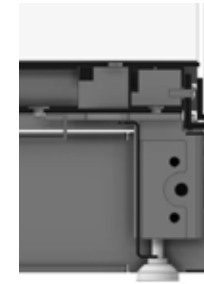

Base frame

Specification of baseboard:

Single-segment element made of metal/aluminum structural profiles, powder-coated in requested RAL color.

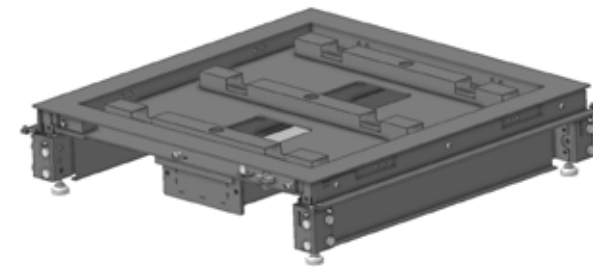

Opening & Access:

Hinged door, French-style opening, with opening restrictor. Opening angle of 110°. Left- or right-hand opening available on request.

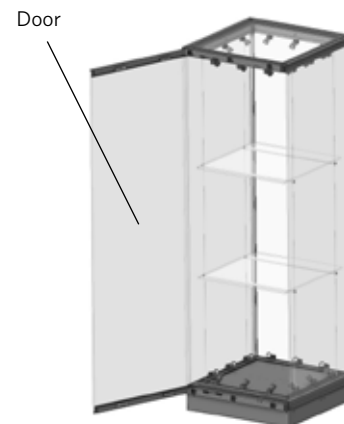

Lighting

Details of the power supply and lighting:

The power cable and electrical compartment are located at the bottom of the display cabinet, concealed by a removable plinth. The lighting system is fitted with a manual dimmer switch with external access. Each module is equipped with independent electrical modules.



Power supply location

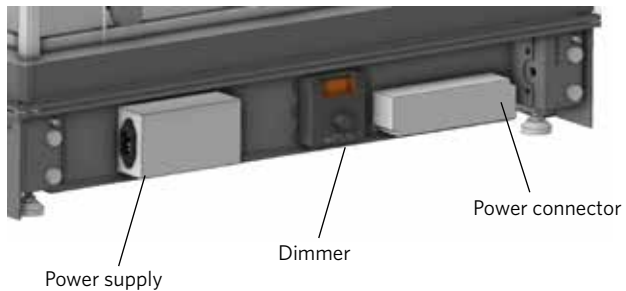

Shelving

Shelving units with a suspension system:

The shelving units can be fitted with up to two glass shelves. The system consists of taut stainless steel cables fitted with clamps to prevent any sideways swaying.



Shelves:

- 10 mm thick extra-clear glass
- maximum load of 10 kg per shelf



Climate control

Passive climate control:

The climate control system is regulated by a desiccant unit to be placed inside the drawer (separate access from the display cabinet). A removable panel conceals this technical compartment.

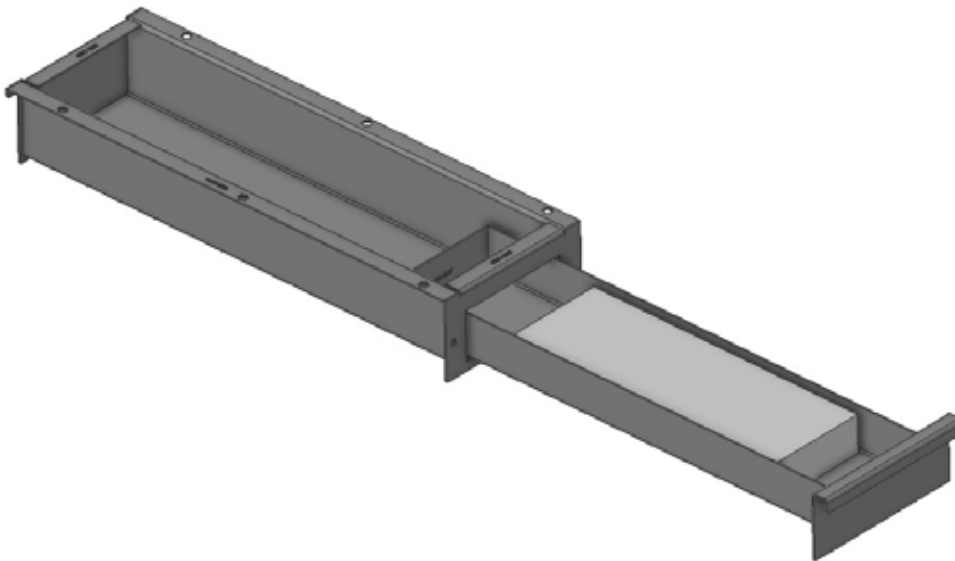
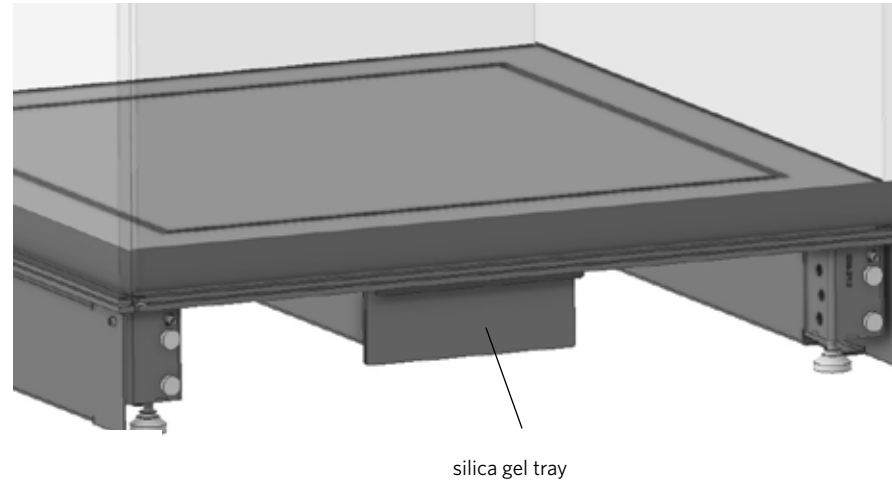

The silica gel drawer can hold two 950 g Prosorb® cartridges (333 x 110 x 43 mm). A separate compartment accessible via the base of the display cabinet.

Air exchange rate (AER): 0,1 air exchange per day







FRANK America Inc.
7702 Backlick Rd.
Suite O Springfield,
VA 22150
United States

Contact:

Dylan Hammond

Tel.: +1 703-867-9808

hammond@frank-america.com

